



DRILLING SWIVEL VB-200R1

Swivel is designed to retain a rotating drilling and other tool hanging with simultaneous supply of the operational fluid from the pump to the pipe string under drilling and oilfield enterprise conditions.

The swivel consists (Fig. 1) of the housing 1 with the feed line 2, a link 3, installed in the lugs of the housing 1 with the possibility of swinging on the pivot studs 4, a stem 5 with the sub 6 mounted on the bearings 7, 8 and 9 with rotation in the housing 1, and the upper 10 and lower 11 seals. The top seal 10 is quick-detachable and is connected to the feed 2 and stem 5 with the nuts 12.

Main technical features:

	VB-200R1-01
Maximum load on the stem, kN (tf)	2000 (200)
Maximum dynamic load on the stem, kN (tf) at a rotation speed of no more than 100 rpm	1120 (112)
Working pressure, MPa (atm)	35 (350)
Stem maximum rotations c ⁻¹	4.17
Stem feedthrough hole diameter, mm	75
Feedline feedthrough hole diameter, mm	75
Adapter sub feedthrough hole diameter, (D1), mm*	80
Stem coupling thread as per GOST 50864-96	Z-133 Left
Coupling thread on the adapter - tool-joint thread as per GOST 50864-96*	Z-152 Left
Coupling thread of the side feedline as per GOST 633-80	NKT 89
Coupling thread on the feedline under the measure while drilling as per GOST 633-80	NKT 60
Operating ambient temperature, °K (°C)	233 (-40)÷343 (+70)
Weight, kg, max.	680

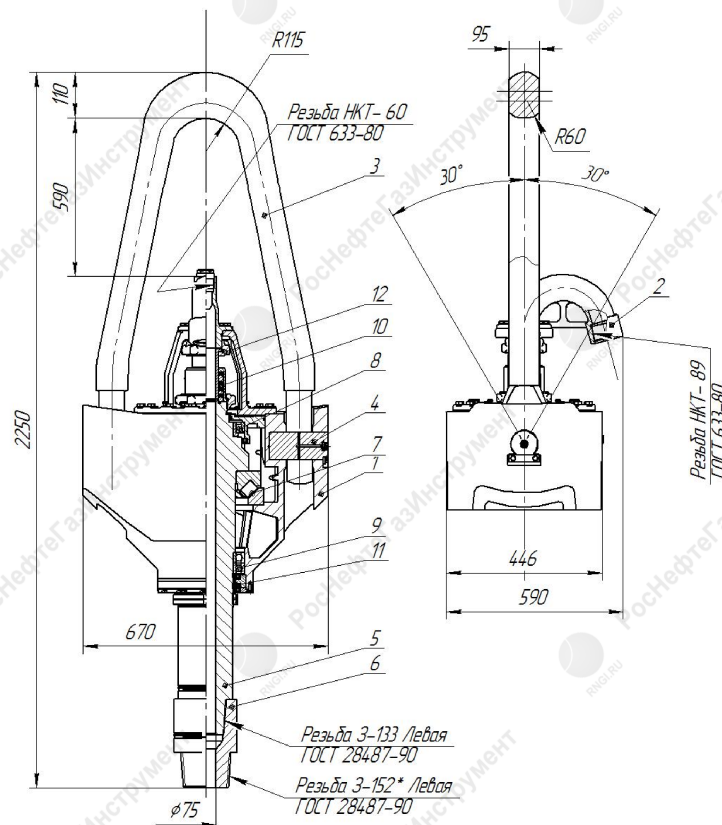

Fig. 1



Main technical features of the stem sub:

Table 2

Adapter sub	Tool-joint thread GOST 50864-96	D1, mm	Assembly you need
VB-200R1.00.26	Z-102 Left (lifting capacity 160 tf)	54	<input type="checkbox"/>
VB-200R1.00.31	Z-108 Left (lifting capacity 170 tf)	54	<input type="checkbox"/>
VB-200R1.00.32	Z-117 Left	58	<input type="checkbox"/>
VB-200R1.00.27	Z-122 Left	70	<input type="checkbox"/>
VB-200R1.00.25	Z-133 Left	80	<input type="checkbox"/>
VB-200R1.00.09	Z-147 Left	80	<input type="checkbox"/>

Feedline subs (fig. 2) and BRS2” sub (fig. 3) may be delivered at consumer's request.

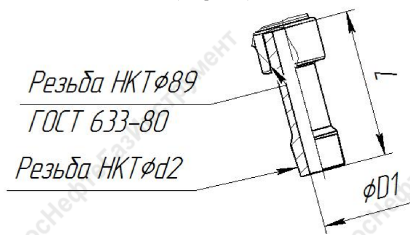

Figure 2

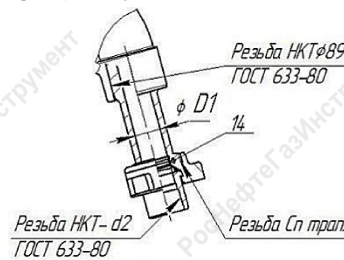

Figure 3

Main technical features of NKT (pumping and compression pipe) adapter subs to the feedline:

Table 3

Adapter sub	L1, mm	D1, mm	Thread NKT d2	Drawing	Assembly you need
NKT89 – NKT114	260	60	114	2	<input type="checkbox"/>
NKT89 – NKT89	252	60	89	2	<input type="checkbox"/>
NKT89 – NKT73	212	50	73	2	<input type="checkbox"/>
NKT89 – NKT60	212	50	60	2	<input type="checkbox"/>
NKT2”	285	50	60	3	<input type="checkbox"/>
BRS2.5”	300	62	73	3	<input type="checkbox"/>
BRS3”	315	75	89	3	<input type="checkbox"/>

Completeness:

- 1) Drilling swivel VB-200R1-01– 1 pce;
- 2) Set of spare parts kit**:
 - Nozzle VB-200R1.01.01– 1 pce;
 - Pump bucket VB-200R1.12.06 – 8 pcs;
 - Ring 095-105-58-2-3 GOST 18829-73 – 2 pcs;
- 3) Operating instruction – 1 pce;

*As per consumer's request it is possible to produce a sub with other technical features (see. table 2)

**As per consumer's request it is possible to deliver an additional or extended set of spare parts kit.