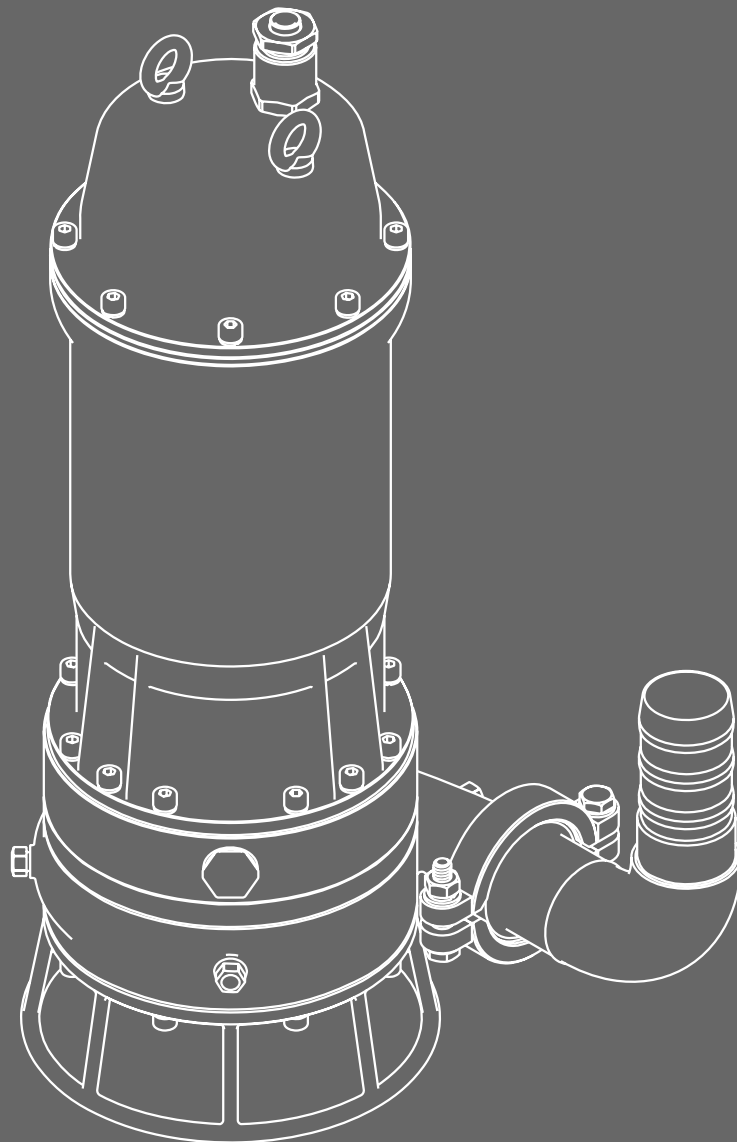




RNGI



Submersible pumping station

---

**SN-3.11.2,1R1-03.50.15.2,2.2T**

rngi.net

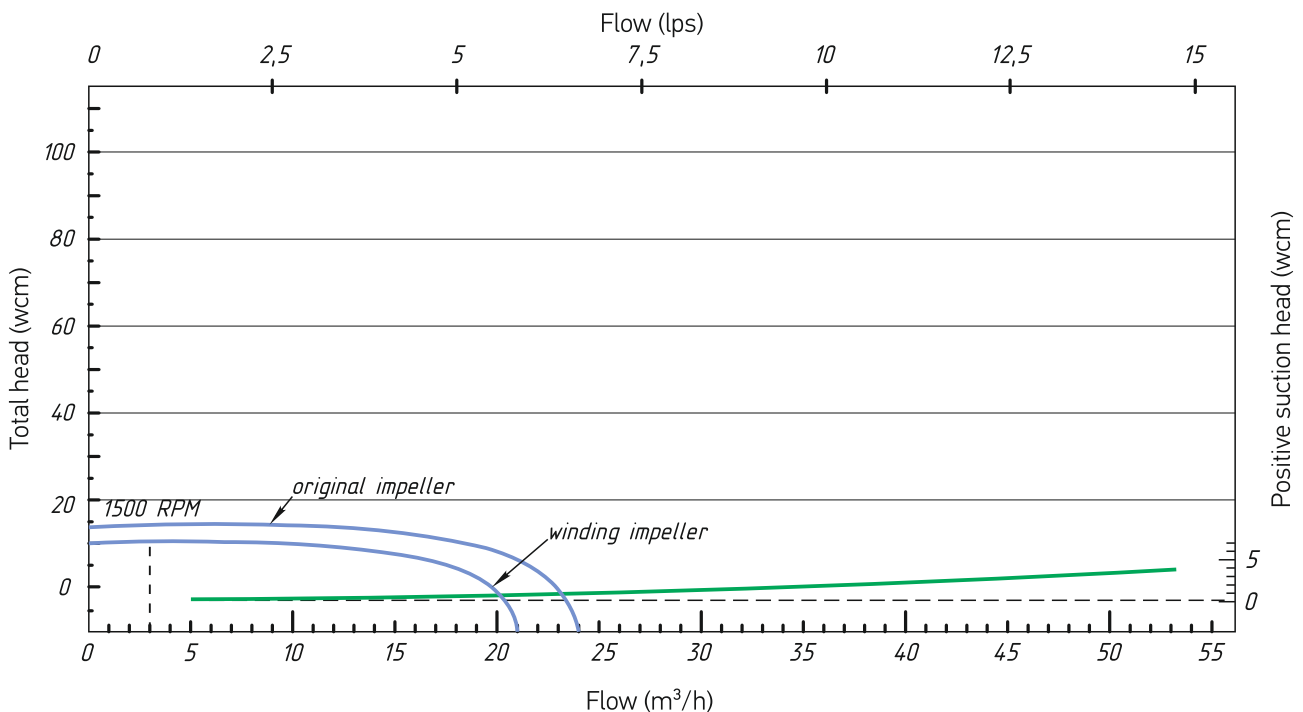
## SUBMERSIBLE PUMPING STATION SERIES SN-3.11.2,1R1-03.50.15.2,2.2T

Submersible pumping station SN-3.11.2,1R1-03.50.15.2,2.2T are intended to:

- to pump abrasive hydraulic fluids (clay and gravel mortars, mixtures of water and sand, ore, etc.);
- to swamp drainage, unwatering of foundation, drainage of lakes and other water bodies;
- to bottom dredging, bank alluviation, desliming and etc;
- for maintenance and repair of gas pipelines in swampy and flooded areas;
- for pumping drill cuttings (cuttings slurry, waste drilling mud), blackwater, industrial waste-water, oil contaminated soil, process effluent of oil-production enterprise and oil refinery;
- for pumping domestic and industrial wastewater with long-fibre, coarse and solid inclusions.

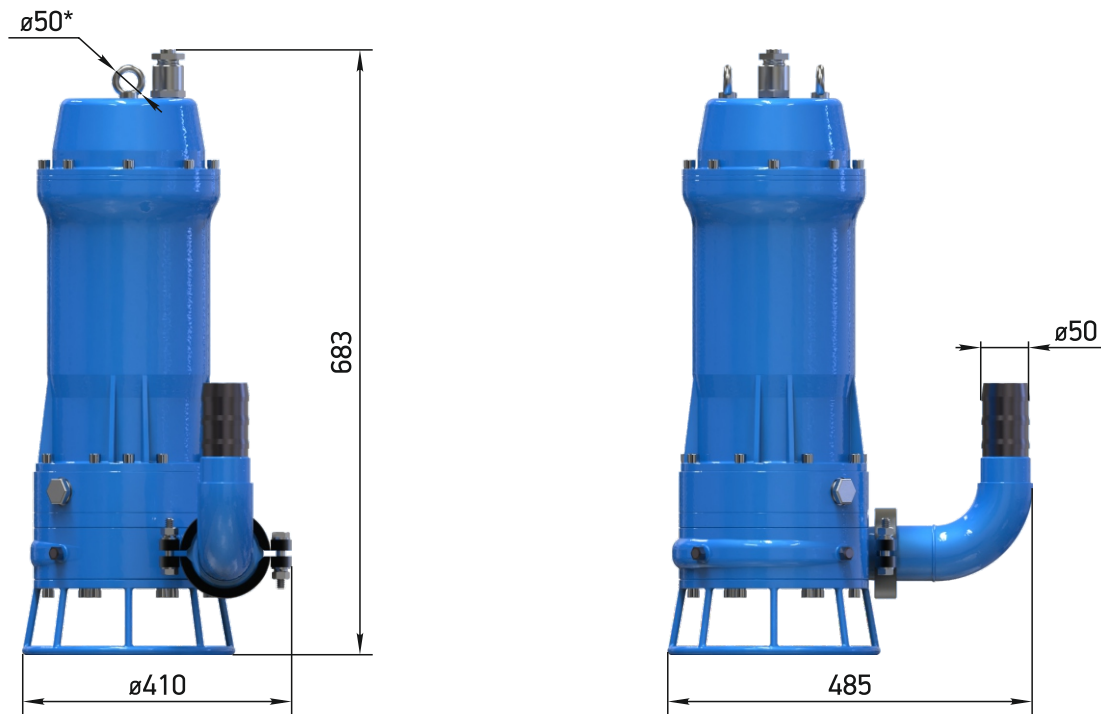


Figure 1.



Graph 1 - Graph of the pump shaft rotation speed and power consumption\* for a density of 1000 kg/m<sup>3</sup>

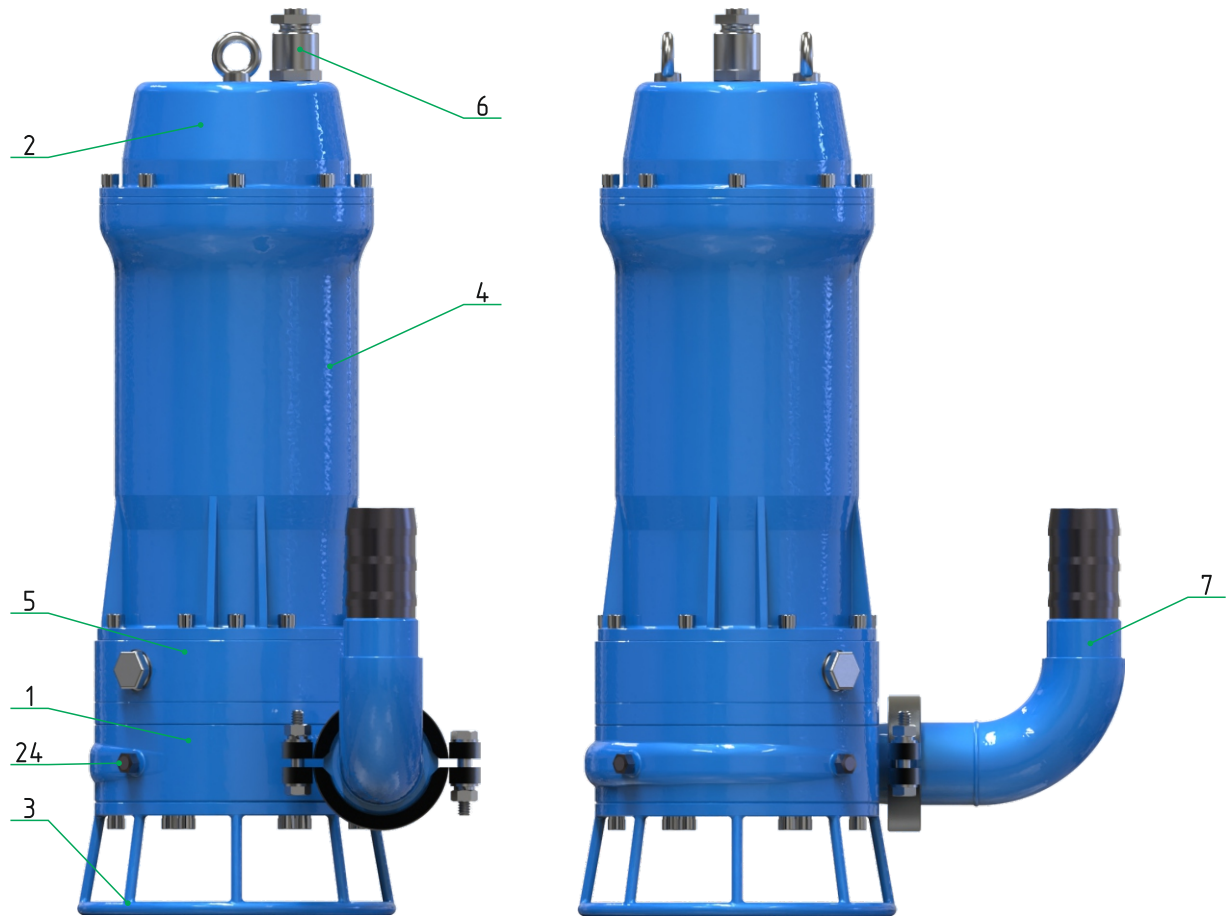
\* When pumping a working fluid of a different density, it is necessary to recalculate the power consumption by multiplying the power consumption value taken from the graph by the specific gravity of the pumped liquid.



Picture 2 - Pumping station SN-R1-03. Dimensions.

### Technical specifications of pumping station SN-R1-03

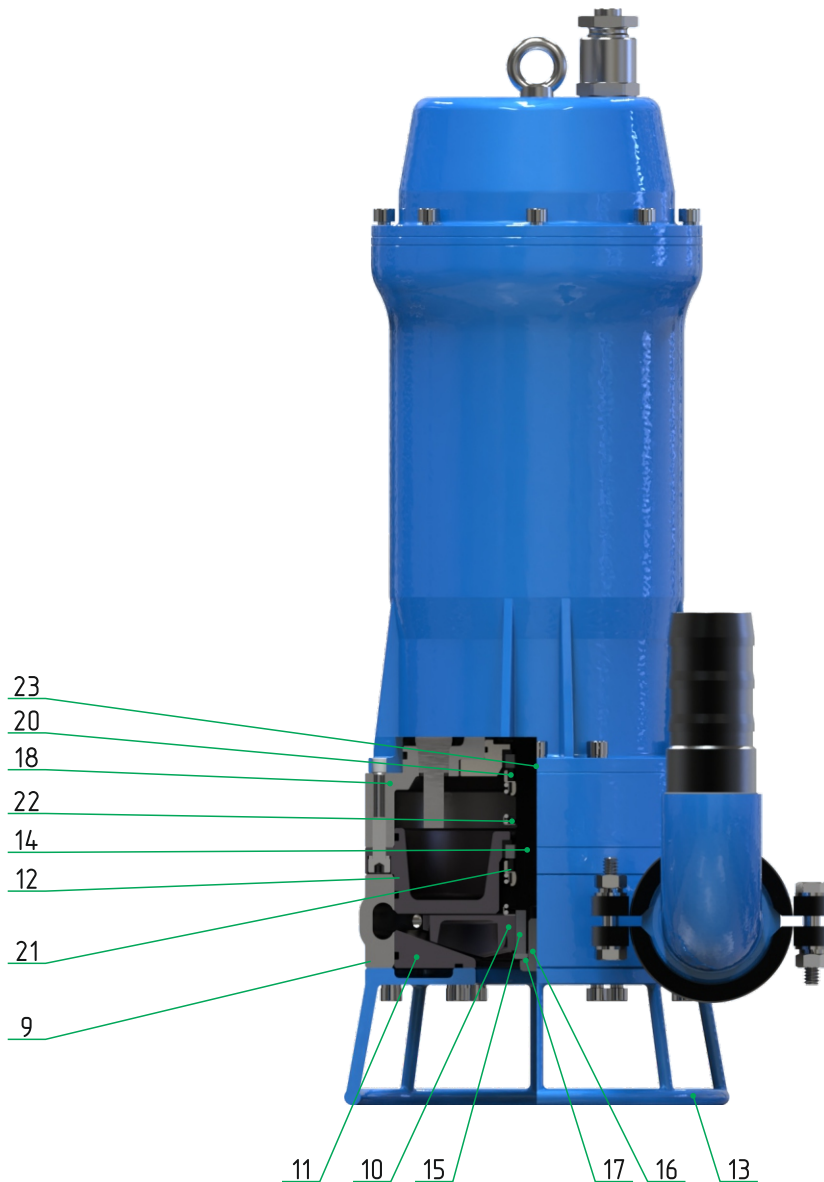
<p><b>Pumped fluid properties:</b>            hydraulic fluid density, <math>\text{kg}/\text{m}^3</math>            temperature, <math>^{\circ}\text{C}</math>            solid particle content            solid particle maximal size, mm</p>	<p>SN-3.11.2,1R1-03.50.15.2,2.2T            up to 2100            +5 ... +20            up to 60%            at most 4</p>
<p><b>Attributes:</b>            Max head, wcm (bar)            Rated head, wcm (bar)            Max flow, <math>\text{m}^3/\text{h}</math> (lps)            Rated flow, <math>\text{m}^3/\text{h}</math> (lps)            Discharge manifold DN, mm            Dimensions, LxBxH, mm            Depth capability, m            Station weight, kg, <math>\pm 3\%</math></p>	<p>11 (1,1)            11 (1,1)            21 (5,83)            3 (0,83)            50            485x410x683            20            55</p>
<p><b>Electric motor:</b>            Power, kW            Rate speed, rpm            Rated current, A            Characteristic curve</p>	<p>2,2            1500            5,08            380V/50Hz</p>



Picture 3 - Pumping station SN-R1-03. Structure.

Pumping station SN-3.11.2,1R1-03.50.15.2,2.2T (Pic. 3) is a device consisting of a centrifugal pump NC-50R1 (pos. 1) installed on an electric motor (pos. 2). A cover with a diffuser (pos. 3) is installed on the inlet pipe of the pump. A casing with a sling eyelet (pos. 4) is installed on top of the electric motor, which provides the degree of protection of the electric motor IP 68. The electric motor and the pump are interconnected by an adapter (pos. 5). The wire for powering the electric motor is led out through the sealer (pos. 6) installed on the casing (pos. 4). A branch is installed at the outlet of the pump (pos. 7).

The pumping station is controlled from an electrical cabinet in which a frequency converter is installed (optional).



Picture 4 - Pumping station SN-R1-03. Structure.

The centrifugal pump NC-50R1-03 (pic. 4) consists of a volute (pos.9), in which there is an impeller (pos.10) and a wear disk (pos.11). A body (pos.12) and a cover with a diffuser (pos.13) are attached to the volute on both sides. The impeller is mounted on the motor shaft (pos.14) through the key (pos.15) and fixed with a bolt (pos.16) using a washer (pos.17). The adapter (pos.18) contains a sealing assembly.

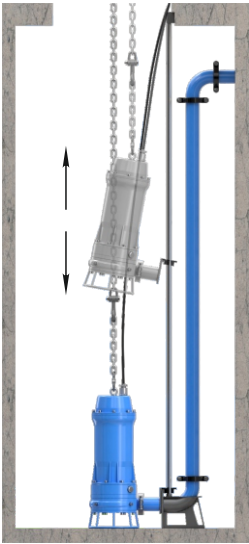
The sealing assembly consists of upper and lower mechanical seals (pos.20 and 21). The upper mechanical seal is pressed by the sleeve (pos.22). Seals require lubrication and cooling to function properly. A plug is provided for filling lubricant. To drain the oil from the cavity between the electric motor and the adapter there is a plug (pos.23).

For flushing the flow part of the pump, there are 4 plugs (pos.24) on the volute.

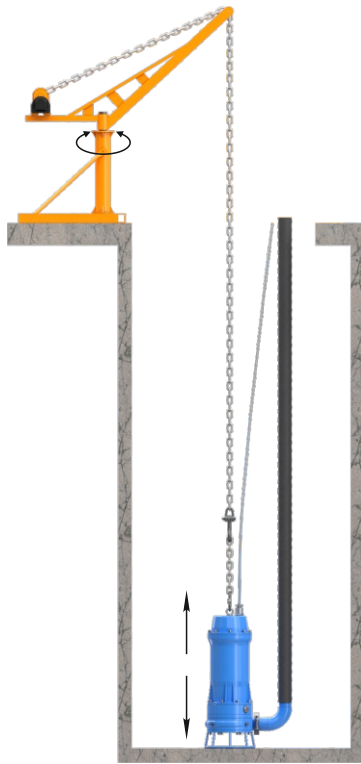
Pumping station SN-R1-03. Additional options.

Pumping station control panel IP 54 (+5 ... +40°C)	<input type="checkbox"/>
Pumping station control panel IP 66 in an explosion-proof design ExdIIBU (-60 ... +50°C)	<input type="checkbox"/>
Frequency converter (FC) for smooth control of the speed of rotation of the motor shaft. Installed in the control cabinet. Allows you to save up to 50% of electricity in variable operating modes.	<input type="checkbox"/>
Cabinet heating at low temperatures (at -40°C)	<input type="checkbox"/>
Motor choke to reduce interference from the frequency converter to the motor	<input type="checkbox"/>
Line choke to reduce interference from the frequency converter to the line	<input type="checkbox"/>
Oil chamber water sensor	<input type="checkbox"/>
PTC motor temperature sensor	<input type="checkbox"/>
Stainless steel metalware	<input type="checkbox"/>

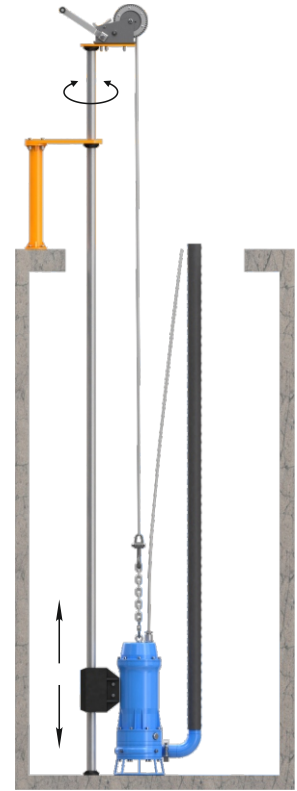
Varieties of submersible pumping station installation SN-R1-03



Picture 5



Picture 6



Picture 7

Stationary installation with automatic coupler (pic.5)	<input type="checkbox"/>
Vertical mounting on support cage (pic. 6)	<input type="checkbox"/>
Vertical mounting with guide support (pic. 7)	<input type="checkbox"/>

Delivery set of submersible pump station installation SN-R1-03

Stainless steel chain for mounting/dismounting the pumping unit, length 10 m	<input type="checkbox"/>
Power cable for connecting the pumping unit, 20 m	<input type="checkbox"/>
Guide with mounting kit, guide length 6 m	<input type="checkbox"/>
Automatic coupling device	<input type="checkbox"/>
Device for raising/lowering the pumping unit (winch)	<input type="checkbox"/>
Discharge pipe for connection to a pressure pipe	<input type="checkbox"/>
Pressure pipe, length _____ m	<input type="checkbox"/>



**RNGI**

phone:  
+7 (861) 212-12-05

e-mail: [manager@rngi.net](mailto:manager@rngi.net)  
[www.rngi.net](http://www.rngi.net)

