



## POU packer for mouth crimping

POU type packers for mouth crimping (hereinafter referred to as packers) are used to verify the leak-tightness of casing string surface part and mounted blowout equipment at pressure, which may occur in case of gas-oil showing, emissions and open flowing, taking into account the auxiliary pressure needed for their elimination.

A packer consists of a hollow shaft (fig. 1), on which a self-sealing pump bucket 2 is mounted with the aid of ring 3, plug 4 and gland nut 5. Above and below the pump bucket positive centralizers are placed indicated by 6 and 7. Sub savers, 8 and 9, are screwed on shaft ends.

Made by TS 3663-015-79560377-2009

**Table 1 - Basic parameters and sizes (fig. 1).**

Name	Conventional representation	
	POU-245R1	
Casing string nominal diameter, mm	245	
Proof pressure, MPa	20	
Diameter of pipes that are provided to be used with packer, mm, minimum	89	114
Maximum effort, influencing the drilling pipe on the preventor, ts, incl.:	101	104
- Pressure effort, ts	70	62
- String weight effort, ts*	31	42
Maximum length of the strings descended into the casing string in pressure test, m	1500	
Thickness of the walls of casing strings, for which operation the possible options of the packers supplied are gathered, mm	7,9-11,2	
Packer length L, mm	1030	
Weight, max., kg	110	
Handling medium	Drilling slurry, oil, water, damping fluid	
Ambient conditions, °C	from - 40 to +100	
Inner feedthrough, d, mm	120	
Coupling threaded dimensions:		
- short triangle stem thread as per GOST 632-80 d1, mm;	146	
- adapter sub thread as per GOST 28487-90 d2, mm	Z-133	

\* Calculated for the maximum drilling pipe wall thickness GOST 631-75.

When selecting the pipe wall and the coupling thread, consider cargo capacity.

**Table 2 - Basic dimensions of centering elements and couplings (Fig. 1)**

Labeling	Casing string wall thickness, mm	Centralizer diameter, D, mm	Ring diameter, D <sub>1</sub> , mm	Coupling diameter, D <sub>2</sub> , mm
POU-245R1	7,9 8,9	224,2	223,7	229,8
	10 11,1	219,8	219,3	225,6

The product is attached with operating instructions and certificate.

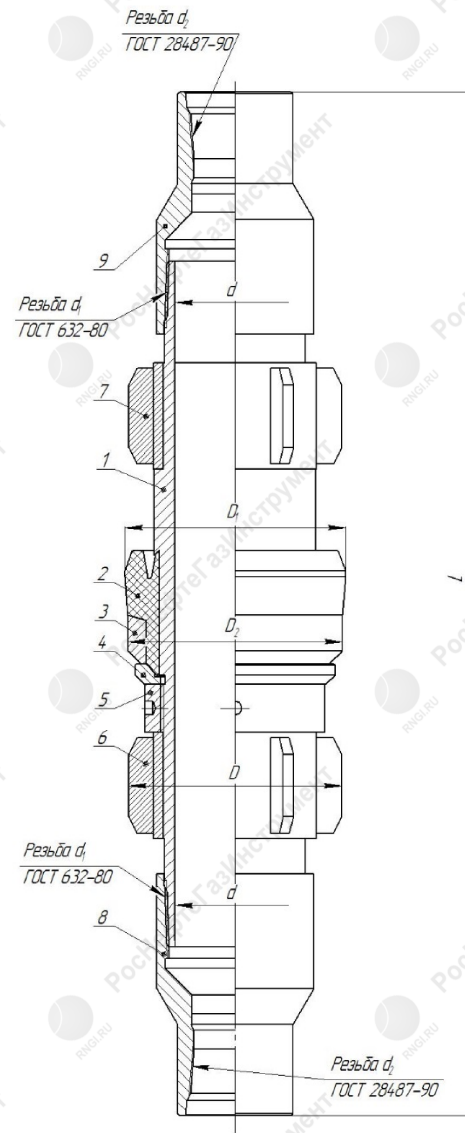

**Fig. 1 POU packer for mouth crimping**