



TECHNICAL PROPOSAL

KO-65xQRC2"R1 Check valve

KO-65xQRC2"R1 check valve is designed for automatic overlap and pressurization of the high-pressure manifold tube channel in cementing, maintenance and operation of oil and gas wells.

The valve consists of (Fig.1) a housing 1, a ball 2, a spring 3, a sleeve nut 4, a stop plug 5, a vessel 6 and a ring 7.

The valve is mounted into the high-pressure manifold, connected to the flange connection with the octangular steel ring gaskets.

The valve opens under the fluid pressure impact in direct feed through the pipe string - ball 2 moves down, in absence of circulation the valve closes under spring 2 impact, the valve closes in case of reverse fluid feed, the stream is cut off.

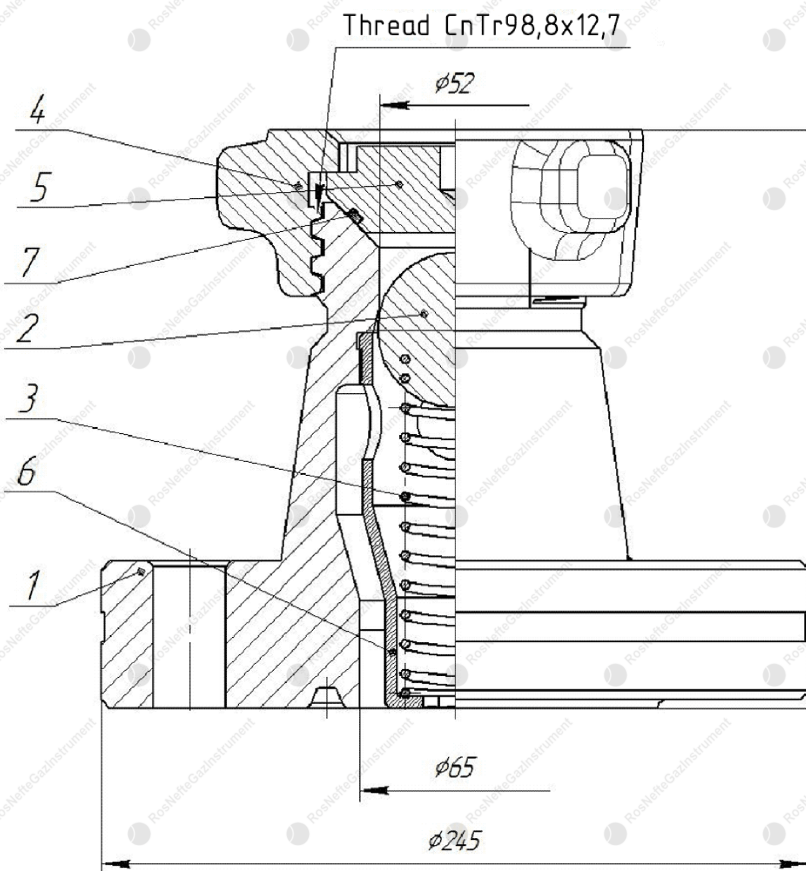

Figure 1.

Technical characteristics:

Working pressure, PSI (Atm.) - 5144 (350)

Cross-section diameter – $\varnothing 2 \frac{1}{16}'' / 52$ mm

Weigh, lbs (kg) - 54 (24,5)

Ambient processing temperature, °K(°C) - 233(-40) ÷ 373(100)

Item material: steel 40X GOST 4543-71

Handling medium: Oil, gas, gas-condensate, flush liquid with CO₂ content up to 6%

Corrosion-resistant design version: K1 as per GOST 13862-90

Ambient class: UHL (HL) as per GOST 15150-69

Connection:

Spec. buttress thread 100x12.7 (swagelok 2")

Flange type 1 65x35 GOST 28919-91